



CONTINUOUS MINER GCM845

Specifications

Operating Dimensions

Mining Range (recommended)	2800 mm- 3900 mm	110.2 in- 153.5 in
Minimum Height Over Cutting Boom Assembly (with 1067 mm (42 in) diameter cutting drum and without bolting rigs)	1800 mm	70.7 in
Maximum Reach (with 1067 mm (42 in) diameter cutting drum and 350 mm (13.8 in) ground clearance)	4150 mm	163.4 in
Ground Clearance	350 mm	13.8 in
Length Rear Bumper to Bit Tip (with 1067 mm (42 in) diameter cutting drum)	8460 mm	27 ft 9 in

Transport Dimensions

Frame Width (outside rub rails and without platforms)	3333 mm	10 ft 11 in
Overall length	11900 mm	39 ft 0.5 in
Height – Cover Line (i.e. without bolting rigs and material pods)	1500 mm	59 in
Weight Standard Machine (total)	92 tonnes	202,800 lb

Cutting Unit

Cutting Drum Diameter	1067 mm	42 in
Cutting Drum Width	Refer to Cutting Width Options	
Cutting Head Speed – Bit Tip (maximum 53 rpm)	2.97 m/s	584 fpm
Cutting Drum Power (one-hour rating)	2 × 173 kW	2 × 232 hp

Traction Units

Crawler Chain Width	559 mm	22 in
Crawler Assembly Length	2850 mm	9 ft 4.2 in
Ground Pressure	230 kPa	33 psi
Crawler Speed	0-0.33 m/s	0-65 fpm
Traction Power DC (one-hour rating)	2 × 56 kW	2 × 75 hp

Electrical System

Machine Voltage	1000 VAC
Control System	Processor Based/ Radio Remote Control

Hydraulic System

Hydraulic Pump Unit (load sensing)	Variable Displacement Pump
Hydraulic Power (one-hour rating)	2 × 67 kW 2 × 90 hp

Bolting System (standard)

Emergency Shutoff	Lanyard on Both Sides of Machine
Roof Bolter Rigs (2 per side)	4 × Units
Roof Bolter Controls	Semi Automatic to MDG 35
Rib Bolters (1 per side)	2 × Units
Rib Bolter Controls (Outbye of Rig)	Semi Automatic to MDG 35
Rib Protection	AROPS

Total Installed Power

Standard (one-hour rating)	674 kW	904 hp
----------------------------	--------	--------

Optional Loading Unit

Loading Method	Plow with Vaned Cutting Unit	
Loading Unit Width	Refer to Cutting Width Options	
Conveyor Width	914 mm	36 in
Conveyor Speed	2.23 m/s	439 fpm
Conveyor Depth (without sideboards)	300 mm	12 in
Loading Capacity	31.5 tonnes/min	35 ton/min
Conveyor Power Tail Drive (one-hour rating)	2 x 29 kW	2 x 39 hp

Loading Unit

Loading Method	6 finger CLA	
Loading Unit Width	Refer to Cutting Width Options	
Conveyor Width	914 mm	36 in
Conveyor Speed	2.23 m/s	439 fpm
Conveyor Depth (without sideboards)	300 mm	12 in
Loading Capacity	31.5 tonnes/min	35 ton/min
Conveyor Power through CLAs (one-hour rating)	2 x 41 kW	2 x 55 hp

Cutting Width Options

Cutting Width	Cutting Drum Width				Loading Unit Width			
	X		Y		Z		W	
4600 mm 181.1 in	4600 mm 181.1 in	4000 mm 157.5 in	4590 mm 180.7 in	3990 mm 157.1 in				
4800 mm 189.0 in	4800 mm 189.0 in	4200 mm 165.4 in	4790 mm 188.6 in	4190 mm 165.0 in				
5000 mm 196.8 in	5000 mm 196.8 in	4400 mm 173.2 in	4990 mm 196.5 in	4390 mm 172.8 in				
5200 mm 204.7 in	5200 mm 204.7 in	4600 mm 181.1 in	5190 mm 204.3 in	4590 mm 180.7 in				
5400 mm 212.6 in	5400 mm 212.6 in	4800 mm 189.0 in	5390 mm 212.2 in	4790 mm 188.6 in				
5600 mm 220.5 in	5600 mm 220.5 in	5000 mm 196.8 in	5590 mm 220.1 in	4990 mm 196.5 in				
5800 mm 228.3 in	5800 mm 228.3 in	5200 mm 204.7 in	5790 mm 228.0 in	5190 mm 204.3 in				

Optional Dust Suppression

Scrubber Type	Wet Bed	
Scrubber Capacity	3.8 m ³ /s-8 m ³ /s	8,000 cfm-17,000 cfm
Scrubber Power (one-hour rating)	1 x 22 kW	1 x 30 hp

Bolting System Options

Custom Package Configuration to Suit Mine Conditions
 (i.e. traversing rigs, east west or north south chuck orientation, TRS)

Electrical System Options

Voltages Available to Suit Different Continents/Countries

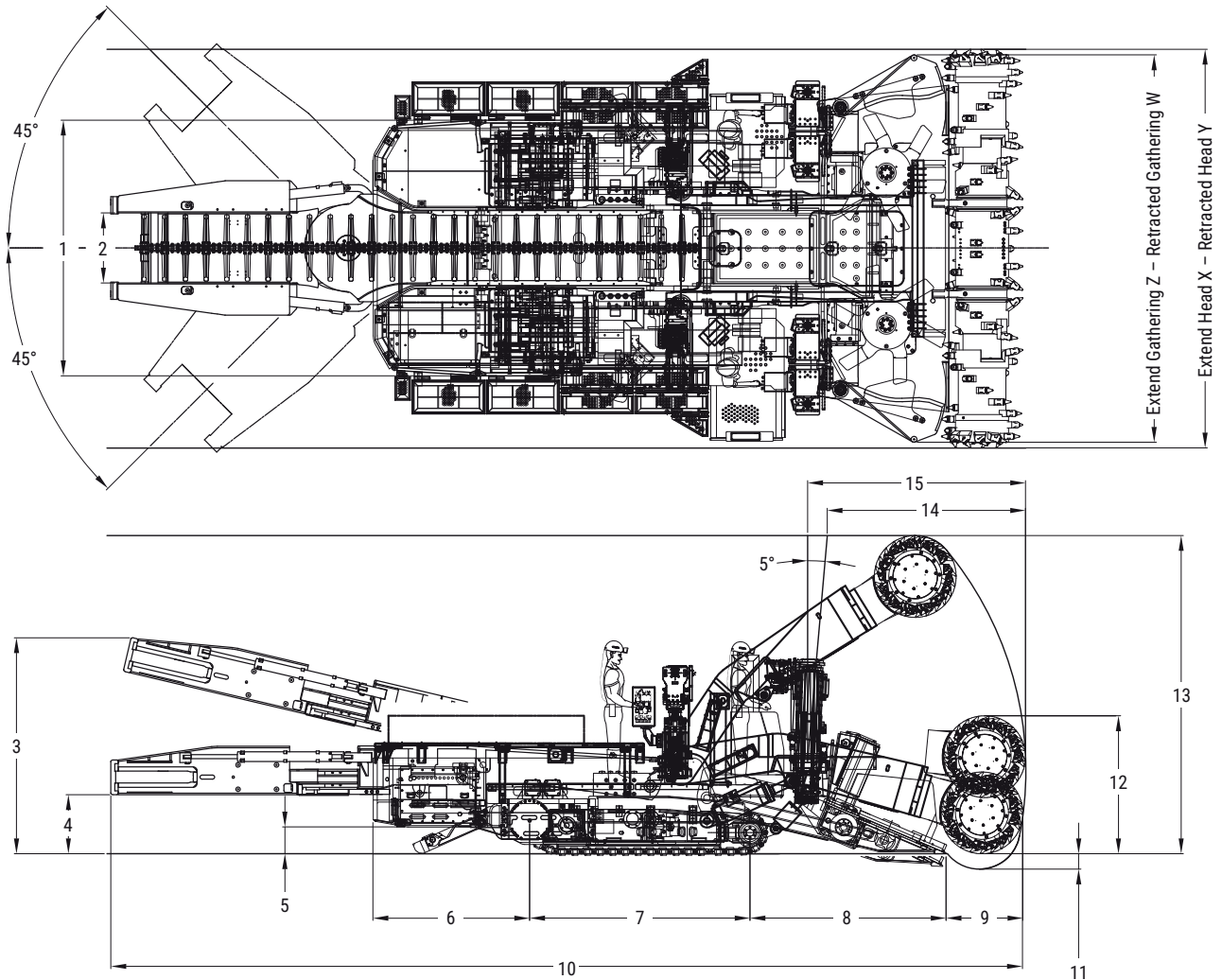

Dimensions (All dimensions are approximate.)

1 Width - without platforms width	3333 mm	10 ft 11 in
2 Conveyor Width	914 mm	36 in
3 Maximum Conveyor Height	2820 mm	9 ft 3 in
4 Height to Bottom of Conveyor	770 mm	30.3 in
5 Ground Clearance	350 mm	13.8 in
6 Length – Rear Bumper to Crawler Sprocket	2050 mm	6 ft 8.7 in
7 Length – Crawler Assembly	2850 mm	9 ft 4.2 in
8 Length – Crawler Idler to Loading Unit Tip	2560 mm	8 ft 5 in
9 Length – Loading Unit Tip to Bit Tip	1000 mm	3 ft 3.4 in
10 Overall Length	11900 mm	39 ft 0.5 in
11 Undercut	200 mm	8 in
12 Zero Cut Height without Rigs	1800 mm	5 ft 11 in
13 Maximum Reach	4150 mm	163.4 in
14 Length – Minimum Bolting Distance to Face	2600 mm	8 ft 6.4 in
15 Maximum Bolting Distance to Face	2850 mm	9 ft 4.2 in

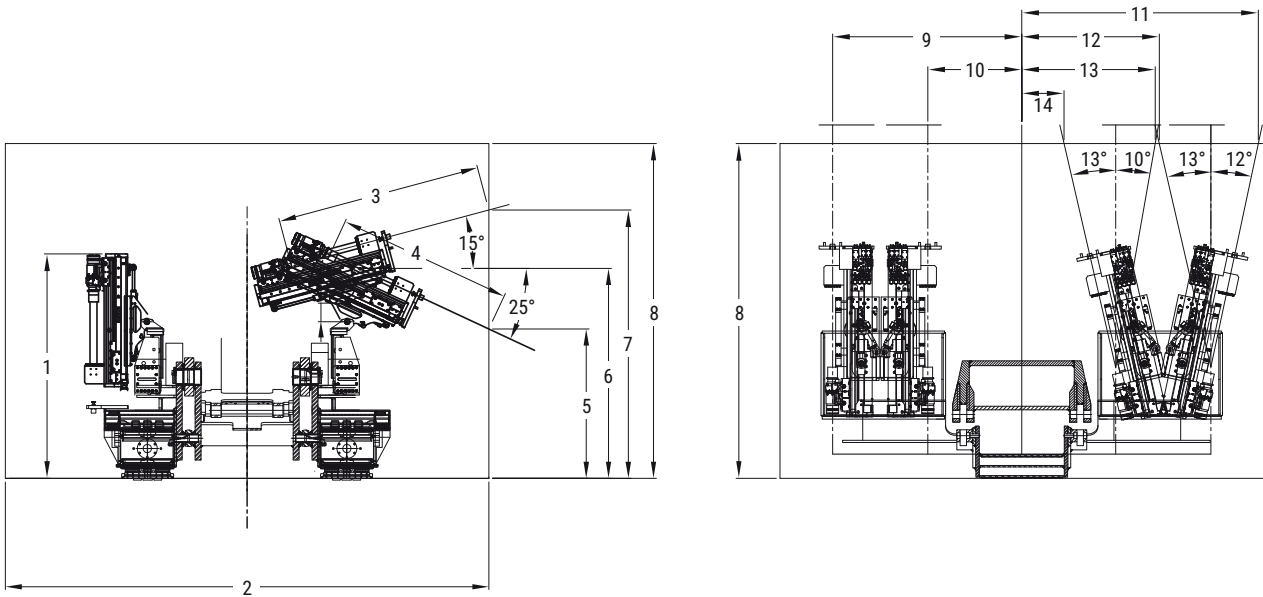

Dimensions (All dimensions are approximate based on the nominal heading shown.)

Height – Top of Rib Bolter in Parked Position	2413 mm	7 ft 11 in
Heading Width	5200 mm	17 ft
Rib Rig – Single Pass Bolt Length with Rig Tilted Up	2205 mm	7 ft 3 in
Rib Rig – Single Pass Bolt Length with Rig Tilted Down	1888 mm	6 ft 2 in
Rib Rig – Minimum Bolting Height	1606 mm	5 ft 3 in
Rib Rig – Nominal Bolting Height	2257 mm	7 ft 5 in
Rib Rig – Maximum Bolting Height	2885 mm	9 ft 6 in
Seam Height	3600 mm	11 ft 10 in
Outer Roof Rig – Nominal Bolting Distance to Machine Centerline	2034 mm	6 ft 8 in
Inner Roof Rig – Nominal Bolting Distance to Machine Centerline	1011 mm	3 ft 4 in
Outer Roof Rig – Maximum Bolting Distance to Machine Centerline	2544 mm	8 ft 4 in
Outer Roof Rig – Minimum Bolting Distance to Machine Centerline	1479 mm	4 ft 10 in
Inner Roof Rig – Maximum Bolting Distance to Machine Centerline	1435 mm	4 ft 8.5 in
Inner Roof Rig – Minimum Bolting Distance to Machine Centerline	454 mm	1 ft 6 in

India

Gainwell Engineering Private Limited
 Godrej Genesis Technology Park
 Unit 401, 402, 403, Plot X1
 Block EP & GP, Salt Lake
 Sector V, Kolkata – 700091, India
 Email : info@gainwellengineering.com

Singapore

Gainwell Engineering Global PTE. Limited
 39 Robinson Road
 #15-01, Robinson Point
 Singapore 068911
 Phone : +65 98706685
 Email : finance@enl.com.sg

Australia

Gainwell Engineering Pacific Pty Limited
 135 Bulls Garden Road
 Gateshead, NSW 2290
 +61 0240721130
 Phone : (02) 4072 1130
 Email : cs@gainwellengineering.com

USA

Gainwell Engineering Inc.
 198 Baughan Road
 HICO, West Virginia, 25854
 United States of America
 Phone: 1-304-658-2100
 Email: inquiries@gainwellengineering.com