

ROOF BOLTER GRB230



Specifications

Dimensions (approximate)

| | | |
|---|--------------------------|--------------------------|
| Overall length with ATRS | 7671 mm | 25 ft 2 in |
| Chassis overall width | 2756 mm | 9 ft 0.5 in |
| Drill boom feed | 2235 mm | 7 ft 4 in |
| Maximum boom separation | 5385 mm | 17 ft 8 in |
| Minimum boom separation | 1168 mm | 3 ft 10 in |
| Minimum tramming height with 32x12.5-15 tires with 35x15-15 tires | 1181 mm 1219 mm | 3 ft 10.5 in 4 ft |
| ATRS reach with 32x12.5-15 tires with 35x15-15 tires | 3010 mm 3048 mm | 9 ft 10.5 in 10 ft |
| Ground clearance with 32x12.5-15 tires with 35x15-15 tires | 203 mm 241 mm | 8 in 9.5 in |
| Chassis height with 32x12.5-15 tires with 35x15-15 tires | 737 mm 775 mm | 2 ft 5 in 2 ft 6.5 in |
| Wheelbase | 2032 mm | 6 ft 8 in |
| Inside turn radius | 2896 mm | 9 ft 6 in |
| Outside turn radius | 6553 mm | 21 ft 6 in |
| Steering articulation | 80° total | |
| Tram speed fast slow | 2.38 m/sec 1.19 m/sec | 0-130 fpm 0-65 fpm |
| Drilling feed thrust (maximum) | 4536 kg | 10,000 lbs |
| Drilling torque (variable) | 420 Nm | 310 ft lbs |
| Bolt tightening torque (adjustable) | 258 Nm | 190 ft lbs |

Drive Train

Four wheel planetary drive; each drive consists of a Fairfield W3B torque hub along with a Char-Lynn series 2000 hydraulic motor.

Automatic Parking Brake

Two spring applied, hydraulic released, fail safe brakes at front of machine.

Hydraulics

Pump

Four stage gear pump rated at 132/132/57/57 L/min (35/35/15/15 gpm) at 1,770 rpm with spline fit to pump motor.

Reservoir:

568 L (150 gal) capacity reservoir with 7 micron return filtration, filter by-pass and "in tank" strainer.

Hydraulic Hose:

All main systems hoses are two wire braid rated at 62MPa (9000psi) burst pressure; MSHA 2g flame resistant approved; all fittings JIC

Sumping Cylinder:

Four (4) 38mm (1.5 in) bore, double acting cylinders two per drilling assembly.

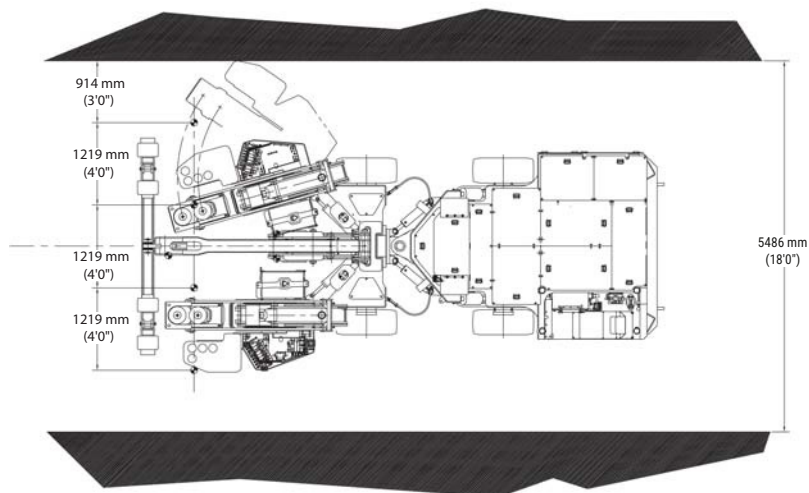
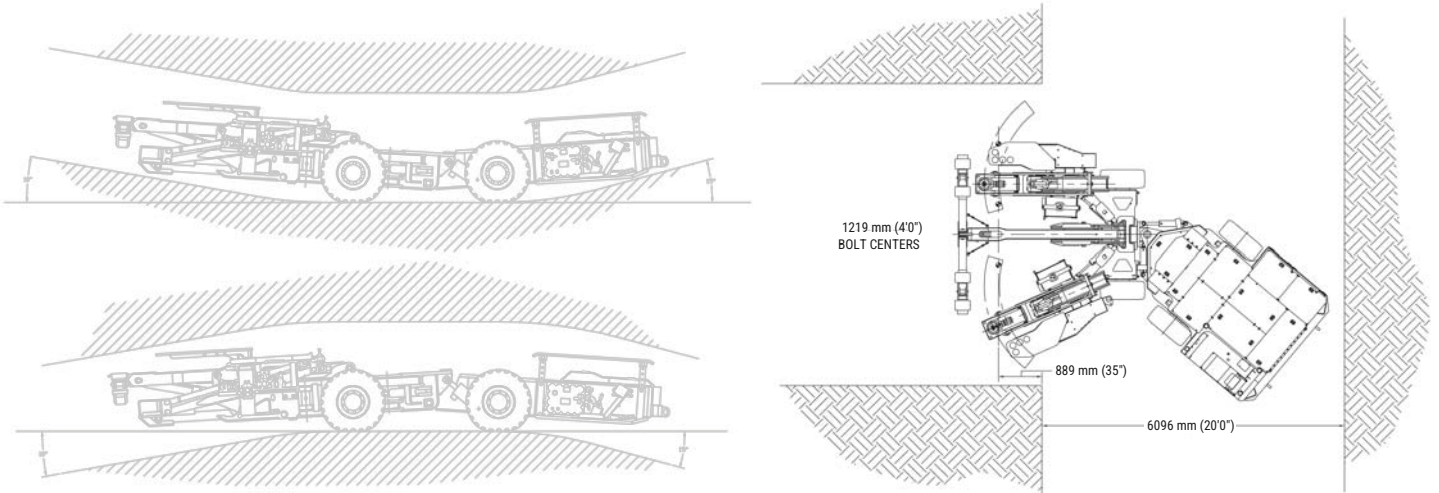
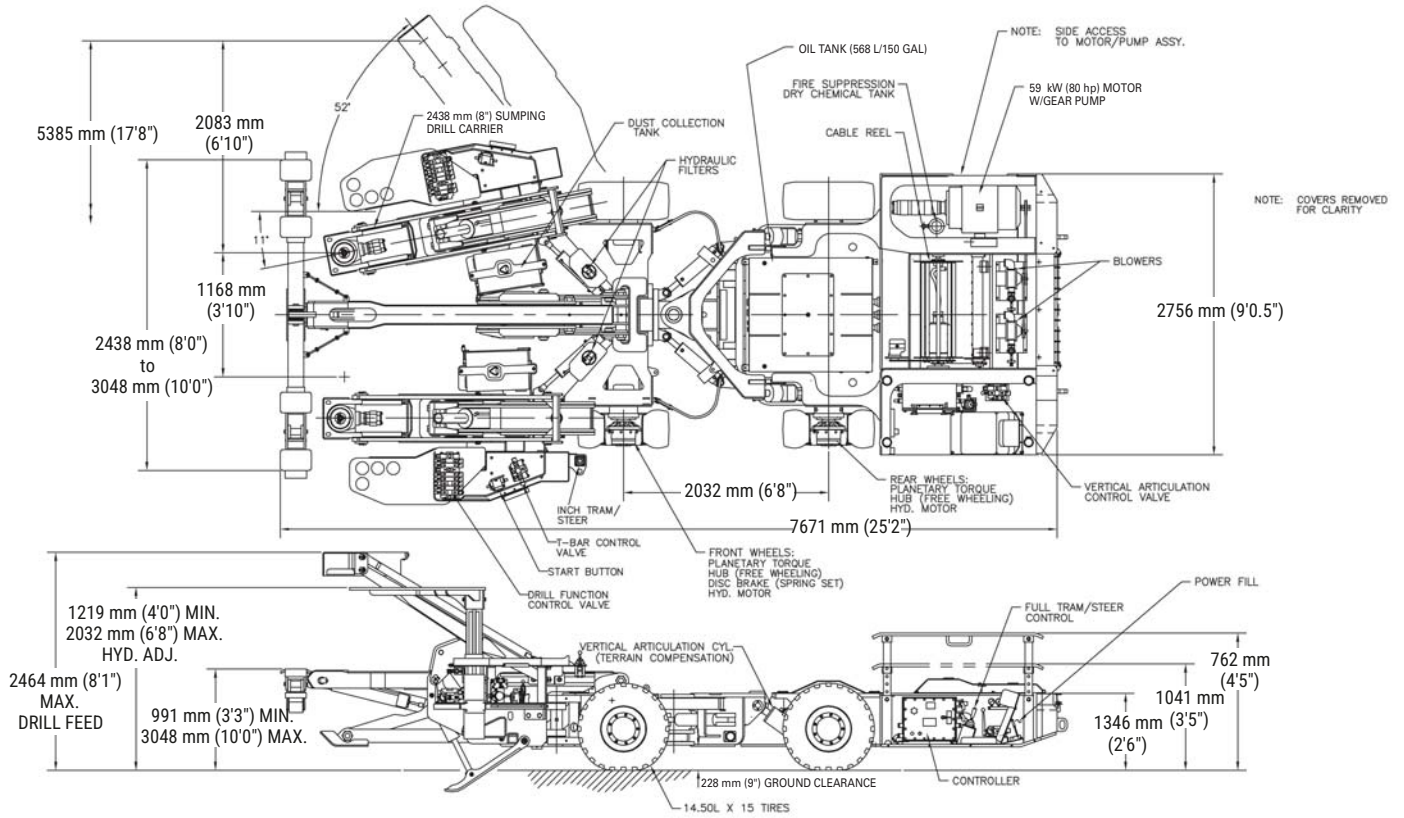

Hydraulics (continued)

Stab Foot Cylinder

- Two (2) 101 mm (4 in) bore, double acting cylinders, one per drilling assembly.

Boom Swing Cylinder

- Two (2) 89 mm (3.5 in) bore, double acting cylinders, one per drilling assembly.

Steering Cylinder

- Two (2) 101 mm (4 in) bore, double acting cylinders.

Boom Feed Cylinder

- Two (2) 165 mm (6.5 in) bore, double acting cylinder on each boom with in the line check valve, one per drilling assembly.

Drill Station Canopy Cylinder

- Two (2) double stage 89 mm (3.5 in) outer bore and 57 mm (2.25 in) inner bore, double acting cylinder per drill station with pilot operated check valve, one per drilling assembly.

Vertical Articulation Cylinder

- Two (2) 152 mm (6 in) bore, double acting cylinders that vary the angle of approach and departure for the rear of the roof bolter from up to 15 degrees rear for improved terrain compensation in adverse conditions.

Valve Banks

- All valve banks are spring returned, bi-directional with main relief set at 13.79 MPa (2000 psi). All other pressures are set for each function accordingly.
 1. One (1) cable reel and vertical articulation valve bank
 2. One (1) steering valve bank controlled by means of a joy stick valve.
 3. One (1) ATRS and vertical articulation valve bank.
 4. Two (2) boom function valve banks, one per drilling assembly.
 5. One (1) tram valve bank controlled by means of a joystick valve in operators compartment.
 6. One (1) inch tram valve bank at rear of operators side drilling assembly.

Electrical

Start

- Push buttons at tram and drill stations.

Stop

- Tape switch (panic strip) at tram and drill stations that de-energize electrical system and applies automatic brake.

Controller

- Size 4 vacuum contactors, 1.5 KVA transformer and 150 amp circuit breaker.

Fire Suppression

- Four point, 9.07 kg (20lbs) tank, multi-purpose, ABC dry chemical fire suppression system manually actuated from operator's compartment and remote location.

Center Section

- Extra strength dual application joint welded from high strength steel with pivot pins; complete with applicable to reduce the thrust bearings.

Frame

- Low profile with bends utilized where applicable to reduce the number of indeterminate stresses introduced by welding.

Operator's Drill Station Area

1. Hydraulically operated drill boom and stab foot functions.
2. ATRS function control and all other positioning function control.
3. 25 mm (1 in) thick, hydraulically adjustable drill station canopy on each drilling assembly.
4. Storage tool tray on each boom for drill steel, starter steel, drill bits and etc.
5. Inch tram function control (left hand drilling assembly only).
6. Vertical articulation function control.

Tram Station Area

1. 25 mm (1 in) thick manually adjustable canopy.
2. Heavy duty seat.
3. Full tram function control.
4. Steering function control.
5. Vertical articulation function control.
6. Cable reel function control.
7. Four pressure gauges.
8. Power fill function control.

Reservoir Fill System

- Power hydraulic fill, allows hydraulic fill, allows hydraulic oil to be reservoir without hand pumping.

Manual

- Two parts manuals.
- Two operation/maintenance manuals/troubleshooting guides.
- One LinkOne CD which includes all above manuals in electronic format.

Miscellaneous

- Seven (7) oil sampling kits.

Roof Bolter Options (must choose)

Voltage/Blower Option

440 Volt AC, Roots Whispair Blower - electrical system with pump motor rated at 80 hp; blowers rated at flows to 81 CFM at 508mm (20") Hg. Each Vacuum blower is directly belt driven from the electric motor by means of sheaves and "v" belts.

Lighting Option

MCI Fluorescent Lighting, High - area lighting with one headlight on front and rear for high seam applications up to 3048 mm (10 ft).

Cable Reel Option

610 mm (24 in) diameter for #2/3C Round Cable - 106 680 mm (350ft) capacity horizontal type reel with free payout and hydraulic motor, chain drive wind in for recommended #2/3C, GGC round trailing cable. Unit is supplied with 6096 mm (20ft) of recommended cable.

Tram Canopy Option

Tram Canopy, 1117 mm (3 ft 8 in) minimum height - manually adjustable tram canopy with a minimum height of 1168 mm (3ft 10in) and a maximum height of 1397mm (4ft 7in) at 216mm (8.5 in) ground clearance.

Drill Chuck Option

Universal, Extended Dry/Deep Splined Chuck - chuck protrudes above drill head by 61mm (2.375 in) with no need for drill chuck retention.

ATRS Option

3226mm (10ft 7in) reach, 3480mm (11ft 5in) to 4115mm (13 ft 6 in) Wide Sumping Crossbeam - T-Bar with hydraulic sump roof support contact rocker arms to allow crossbeam to extend from 3480mm (11ft 5in) to 4115mm (13ft 6in). This T-bar consists of a primary and secondary cylinder along with two 305mm (12in) sumping cylinders.

Tire/Wheel Option

Four 35x15-15, 889 mm (35 in) Foam Filled Tires - 20 ply, 889 mm (35 in) maximum form diameter foam filled tires mounted on rim assemblies.

Drill Speed Option:

650 RPM Maximum Drill Speed – generated by means of a 32mm (1.25in) gear width hydraulic motor.

Controller Cover/Oil Level Switch Option:

Oil Level Switch, Light Only - above cover assembly with the addition of a low oil warning light.

Oil Filter Brand Option:

Schroeder "Spin-On" Oil Filter – 7 micron return side filter. The filter is equipped with by-pass and external dirty filter indication.

Blower Exhaust Location Option:

Left Side, Operator's Side - at rear of machine.

Roof Bolter Accessories:

- Pre-Duster Installation - remote tank with a 122 m³ (0.4 ft³) capacity that removes larger dust particles automatically, when stab cylinder is activated.
- One Hand Rotation/Drill Feed Control Installation.
- Schroeder Test Mate Installation – four test ports, one for each stage of the main hydraulic pump.
- Grease Zone Lubrication Installation
- Torque Gauge Installation – monitor the amount of torque being applied to the roof bolts during installation (one gauge for each drilling assembly).

India

Gainwell Engineering Private Limited
Godrej Genesis Technology Park
Unit 401, 402, 403, Plot X1
Block EP & GP, Salt Lake
Sector V, Kolkata – 700091, India
Email : info@gainwellengineering.com

Australia

Gainwell Engineering Pacific Pty Limited
135 Bulls Garden Road
Gateshead, NSW 2290
+61 0240721130
Phone : (02) 4072 1130
Email : cs@gainwellengineering.com

Singapore

Gainwell Engineering Global PTE. Limited
39 Robinson Road
#15-01, Robinson Point
Singapore 068911
Phone : +65 98706685
Email : finance@enl.com.sg

USA

Gainwell Engineering Inc.
198 Baughan Road
HICO, West Virginia, 25854
United States of America
Phone: 1-304-658-2100
Email: inquiries@gainwellengineering.com