



**GAINWELL**  
ENGINEERING

# SCOOP GSU488

## Specifications

### Dimensions (approximate)

<b>Overall Length</b>		
With lifting forks	8030 mm	26 ft 4 in
With contoured bucket	8940 mm	29 ft 4 in
With quick-attach flat bottom bucket	9140 mm	30 ft 0 in
Length with lift plate attachment	8230 mm	27 ft 0 in
<b>Overall Width</b>		
With lifting forks	2690 mm	8 ft 10 in
With contoured bucket	2900 mm	9 ft 6 in
With quick-attach flat bottom bucket	2900 mm	9 ft 6 in
<b>Wheelbase</b>	3660 mm	12 ft 0 in
<b>Un-A-Trac Empty Weights</b>		
Less Battery	16 650 kg	36,700 lbs
With 64-SS85-21 Battery	21 200 kg	46,750 lbs
With 64-SS100-21 Battery	21 770 kg	48,000 lbs
<b>Battery Height from Ground</b>		
With 64-SS85-21 Battery		
35X15-15 Tires	965 mm	3 ft 2 in
38X16-15 Tires	1020 mm	3 ft 4 in
With 64-SS100-21 Battery		
35X15-15 Tires	1020 mm	3 ft 4 in
38X16-15 Tires	1070 mm	3 ft 6 in
With 64-SS125-21 Battery		
35X15-15 Tires	1120 mm	3 ft 8 in
38X16-15 Tires	1170 mm	3 ft 10 in
<b>Ground Clearance (Nominal)</b> (Please reference sales drawing for Ground Clearance profile)		
35X15-15 Tires	250 mm	10 in
38X16-15 Tires	330 mm	13 in
<b>Adjustable Cab Height</b>		
35X15-15 Tires	1270 mm-1520 mm	4 ft 2 in-5 ft 0 in
38X16-15 Tires	1350 mm-1600 mm	4 ft 5 in-5 ft 3 in
<b>Main Frame Height</b>		
35X15-15 Tires	860 mm	2 ft 10 in
38X16-15 Tires	940 mm	3 ft 1 in
<b>Inside turn radius</b>	3660 mm	12 ft 0 in
<b>Outside turn radius</b>	7315 mm	24 ft 0 in
<b>Steering articulation</b>	80° total	
<b>Tram Speed</b>	8 km/h	5 mph

### Lift Capacity

14.5 tonne at 914 mm (16 tons at 36 in) from the face of lift plate

### Drive Train

#### Tram Motor

One proprietary design

Mine traction

Direct current

Gear motor rated at 37 kW (50 hp) (1 hour) at 1,540 rpm and 110 Volts

MSHA totally enclosed, explosion-proof

Non-ventilated cooling

Foot-mounted

#### Reducer

A foot-mounted 3.33:1 ratio gearbox

#### Drive Lines

Heavy duty off-highway

7C type driveshafts with slip joints

#### Axles

Heavy duty

35 800 kg (79,000 lbs) capacity axle

Features outboard planetary

SAHR brakes

Brake cooling

Optional Diff-Lock

\*Alternate axles will be considered upon request

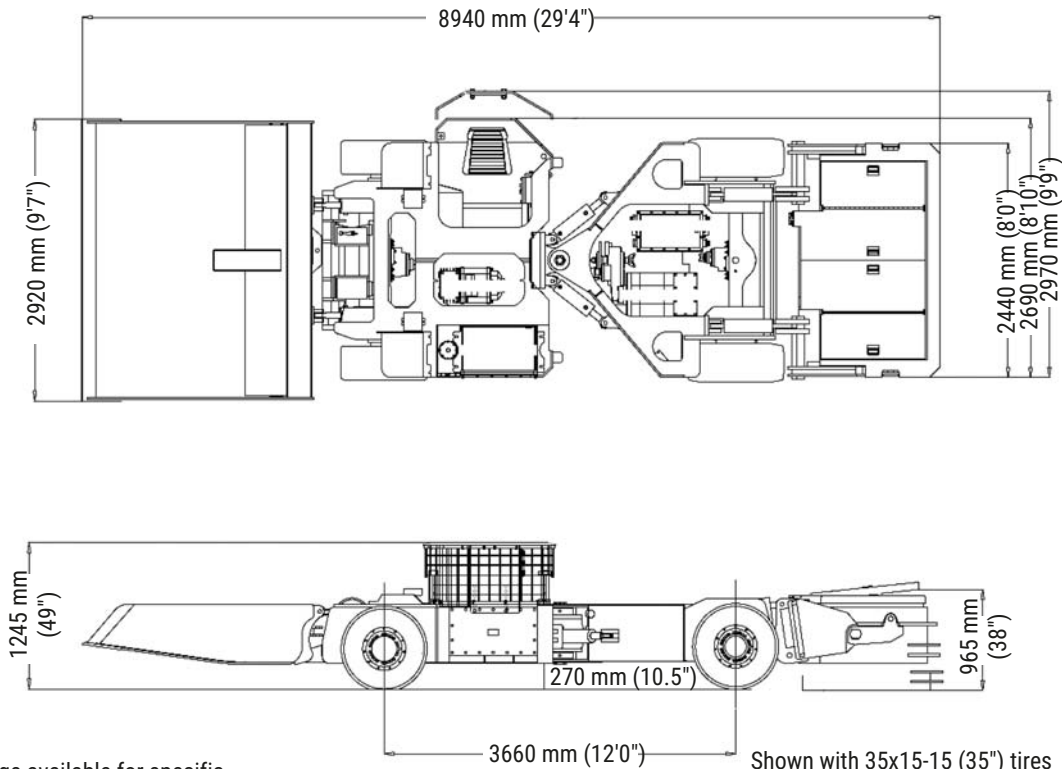

\*Detailed GA drawings available for specific dimensions and component locations

Shown with 35x15-15 (35") tires and 64-SS85-21 battery

## Brakes

### Service & Emergency/Park

- Spring-applied hydraulic release SAHR
- 4-wheel wet disc
- Left-pedal activated
- Controlled by reverse modulating valve

## Hydraulics

### Pump Motor

- Mine duty
- Laminated frame
- Direct current
- Motor rated at 12 kW (16 hp) (1 hour)
- 110 Volts DC
- MSHA totally enclosed, explosion-proof
- Non-ventilated cooling
- Foot-mounted

### Pump

- Fixed displacement
- Helical gear tandem pumps rated at 91 total L/min (24 total gpm) at 1,600 rpm
- Pump is directly mounted to the pump motor housing.

## Hydraulics (continued)

### Reservoir

170 L (45 gal) capacity with magnetic particle sump strainer and 10 micron return line filter with by-pass. A sight glass on the side of the oil tank for oil-level monitoring.

### Reservoir Fill System

Fill cap assembly in top of reservoir tank.

### Valve Bank

Six section, parallel (flow through) type with 15.5 MPa (2,250 psi) internal relief and 11.7 MPa (1,700 psi) steering relief. Valve bank is rated at 151 L/min (40 gpm)

### Hydraulic PTO

Two (2) quick coupler connections, 8.3 MPa (1,200 psi) maximum recommended operating pressure.

### Steering Cylinder

Two (2) 127 mm (5 in) bore, double-acting cylinders with forged rods and self-aligning bearings.

### Lift Cylinder

Two (2) 178 mm (7 in) bore, double-acting cylinders with forged rods and self-aligning bushings.

### Hydraulic Hose and Fittings

JIC fittings with high pressure hoses, MSHA 2G flame-resistant approved.

---

## Fire Suppression

---

Four point, 9 kg (20 lbs), multi-purpose, ABC dry chemical fire suppression system manually actuated from operator's compartment and remote location.

---

## Frame

---

Heavy-duty with bends utilized where applicable to reduce the number of indeterminate stresses introduced by welding; constructed of ASTM 572-GR50 steel with T-1 steel at high stress or wear areas; 254 mm (10 in) extended operator's deck with side egress access.

---

## Center Section

---

Heavy-duty ball bearing with unlimited oscillation; internal grease seals to prevent contamination of the ball bearings, and pivot points designed to distribute loads using self-aligning, one-piece, heavy-duty radial bearings.

---

## Operator's Compartment

---

1. 254 mm (10 in) extended operator's deck
2. Control station which houses the master switch for park, forward and reverse; light switch for front and rear lights; pump motor start button and automatic park brake release
3. Right foot accelerator pedal
4. Left foot brake pedal
5. Tape strip panic switch that de-energizes electrical system and applies automatic brake
6. Warning gong
7. Manual circuit breaker lever reset handle
8. Valve bank hydraulic functions:
  - Steering
  - Bucket
  - Bucket eject
  - Winch/power take off
  - Battery changer
9. System pressure gauge
10. Accumulator pressure gauge
11. Park brake release pressure gauge

---

## Operator Control

---

Left-hand control stick that incorporates the most common operator functions

Ergonomically designed control stick for one-hand control of pump motor, park brake, travel direction, traction assist, stop/shutdown and headlight controls. Speed control accomplished by right-foot-activated pedal. Tapeswitch stop switches located on both sides of operator.

Manual disconnect switch

---

## Electrical Controls

---

1. Model 2000, microprocessor controlled, IGBT, contactorless, 128VDC, 1200 amp traction motor controller with infinity variable, stepless, machine speed control. Equipped with on-board dashboard display for machine information of battery capacity, battery voltage, motor currents, elapsed time hourmeter, and troubleshooting diagnostics information.
2. Microprocessor controlled, IGBT, contactorless, 128VDC, 350 amp, pump motor controller. Limits starting current and provides LED-based diagnostics.
3. Mine duty, 600 amp frame circuit breaker, with UVR (under voltage release) trip unit.

---

## Operator's Compartment Options

---

533 mm (21 in) deck extension to provide better visibility in the lower seams

Hydraulically activated, floor mounted, foot operated push button.

35X15-15 Tires – Customer-specified tire brand and fi

---

## Tire/Wheel Option

---

35x15-15 Tires - Customer-specified tire brand and fill type.

38x16-15 Tires - Customer-specified tire brand and fill type.

---

## Lift Attachment Option

---

QDS quick attach module (required for all QDS attachments)

QDS fork assembly

QDS battery carrier

---

## Winch Option

---

Winch – 13 600 kg (30,000 lb) bare drum pull, two-speed winch assembly with 21.3 m of 19 mm (70 ft of ¾ in) diameter steel cable. Requires operator cab in lieu of canopy.

---

## Cab Options (cab must be utilized when winch is selected)

---

Manual

Hydraulic

---

## Battery Plug – Single Connector Option

---

### J&R 2000, 5-pole, Brass w/Captive Wrench

---

Brass plug with a captive wrench to install or remove the battery plugs. Battery plug is rated at 600 amps.

Other connector options available upon request

---

### Lighting System Option

---

#### Ocenco, Halogen, 12VDC, 50 watt

Two front headlights with protective guard, and two rear headlights with protective guard.

MCI 120V  
MCI 12V

---

### Center Section Cable Location Option

All cables over the top of center section.

Cables are protected with additional guarding and covers. This will add 76 mm (3 in) to overall frame height.

---

### Auxiliary Components

Battery Change Cables

---

### Machine Battery

Battery Tray

Battery with Plastisol Coated Tray (Single Connector)  
Battery Receptacle Kit  
Battery Filling System

---

### Battery Charger Options

Single-output for one battery

Dual-output for two batteries

---

### Battery Charger Accessories

---

#### Heavy-duty Charger Case

Sled consisting of heavy-duty protection framework and equipped with lifting mechanisms designed to be engaged by the optional QDS Lift System.

---

### Other Options

Schroder Test Mate

PA approval kit

Park brake pressure switch

Venturi jet fill

Traction motor over speed protection

Handheld calibrator  
(control adjustments and troubleshooting)

HiPAC 10 control system

#### India

Gainwell Engineering Private Limited  
Godrej Genesis Technology Park  
Unit 401, 402, 403, Plot X1  
Block EP & GP, Salt Lake  
Sector V, Kolkata – 700091, India  
Email : [info@gainwellengineering.com](mailto:info@gainwellengineering.com)

#### Australia

Gainwell Engineering Pacific Pty Limited  
135 Bulls Garden Road  
Gateshead, NSW 2290  
+61 0240721130  
Phone : (02) 4072 1130  
Email : [cs@gainwellengineering.com](mailto:cs@gainwellengineering.com)

#### Singapore

Gainwell Engineering Global PTE. Limited  
39 Robinson Road  
#15-01, Robinson Point  
Singapore 068911  
Phone : +65 98706685  
Email : [finance@enl.com.sg](mailto:finance@enl.com.sg)

#### USA

Gainwell Engineering Inc.  
198 Baughan Road  
HICO, West Virginia, 25854  
United States of America  
Phone: 1-304-658-2100  
Email: [inquiries@gainwellengineering.com](mailto:inquiries@gainwellengineering.com)